

I O M

Install-Operate-Maintain

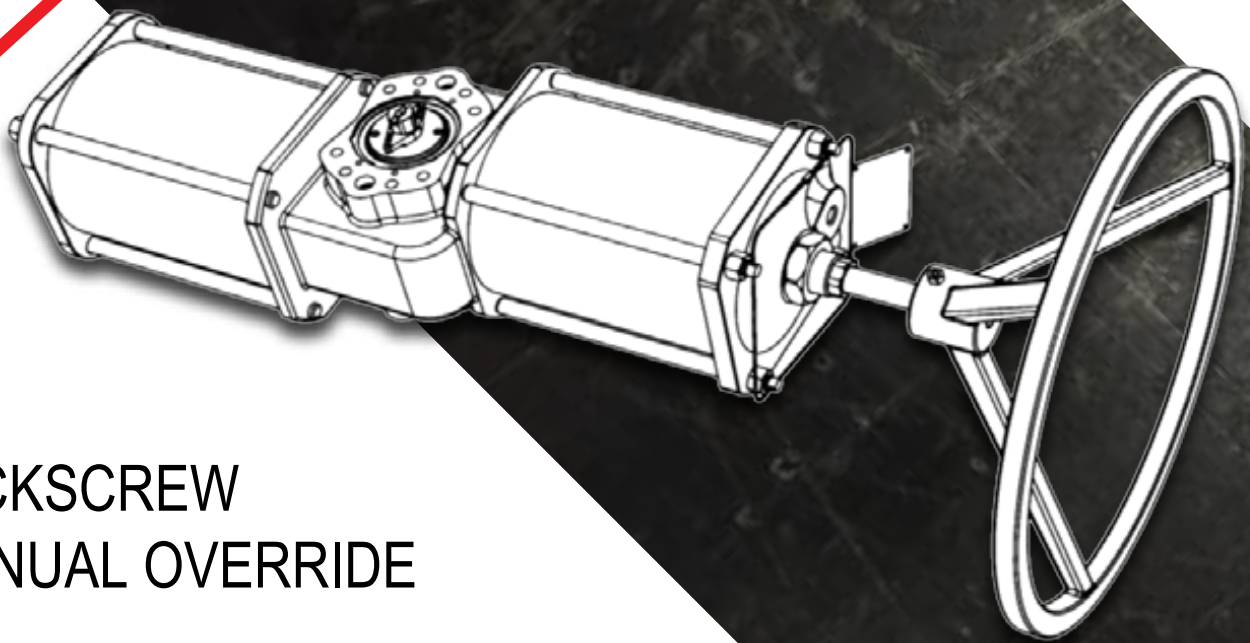

JACKSCREW MANUAL OVERRIDE

This manual describes the proper methods for installation, operation, and repair maintenance.

1.1 INSTALLATION

An appropriately sized jackscrew override can be installed on any Q Series or F Series actuator with an 8" piston or less.

1. Exhaust all pressure and disconnect all supply lines.
2. Loosen all tie rod nuts until they are flush with the ends of the tie rods.
3. Check that there is no pressure against the end cap by verifying that the end cap is not being forced against the tie rod nuts.

WARNING

IF THERE IS FORCE AGAINST THE END CAP, STOP. DO NOT CONTINUE FURTHER UNTIL IT IS ASSURED THAT THE UNIT IS SAFE TO DISASSEMBLE.

4. Note the orientation of the pressure port and remove the end cap. Be careful not to lose the cylinder seal located on the internal side of the end cap.
5. Remove the tie rods, and replace them with the jackscrew tie rods. Place the jackscrew end cap over the tie rods with the pressure port in the correct orientation. Be sure that the cylinder is seated in the cylinder seal groove of the end cap with the cylinder seal still in place between the cylinder and the end cap.
6. Secure the jack screw assembly with the tie rod hex nuts. Hand tighten, and then torque the hex nuts to half and then full values according to the tables below using the pattern designated.

Q Series Actuators

MODEL	LB* FT	Nm
203	10	14
204/205	10	14
207/210	20	27
212/214	35	48

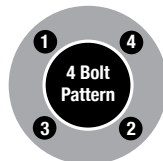

F Series Actuators

Cylinder Size	LB* FT	Nm
6	15	20
8	35	48

7. Thread the safety cable through the holes in the tie rods and the tag. Slide the cable ends into the oval sleeve provided and secure by crimping the oval sleeve.
8. Adjust travel stop on jack screw unit. See 1.2 - Travel Adjustment
9. Leak Test and reinstate the actuator to service

1.2 TRAVEL ADJUSTMENT

For travel adjustment turn the handwheel counter clockwise to the outer most position and then follow the instructions outlined in IOM F2SR or IOM Q2SR available under the resources tab at www.qtrco.com

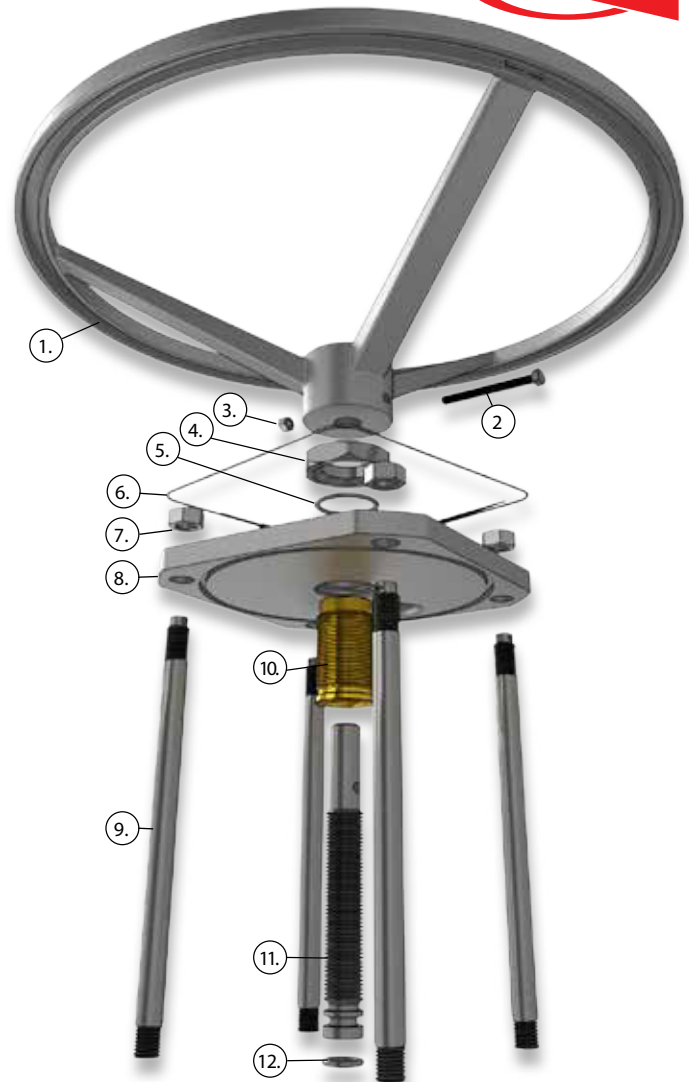

NUMBER	PART	NUMBER	PART
1	Hand Wheel	7	Tie Rod Hex Nut
2	Hand Wheel Bolt	8	Jackscrew End Cap
3	Hand Wheel Hex Nut	9	Jackscrew Tie Rod
4	Travel Stop Nut	10	Jackscrew Travel Stop
5	Jackscrew Sleeve O-Ring	11	Jackscrew Rod
6	Safety Tag Assembly	12	Jackscrew Rod O-Ring

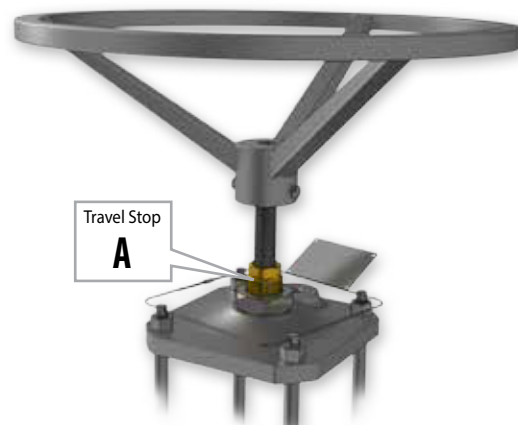

For three years we provide replacement seals free of charge regardless of the number of cycles.



13120 Theis Lane
Tomball, TX 77375
(281) 516-0277

 **888.ACTU.8.IT**
888.228.8848

 **www.qtrco.com**
Email: actu8it@qtrco.com

DCN00789